

CHAPTER 4

PULSE CODE MODULATION STANDARDS

TABLE OF CONTENTS

4.1	General	4-1
4.2	Class Distinctions and Bit-Oriented Characteristics	4-1
4.3	Fixed Formats	4-2
4.4	Format Change (Class II)	4-6
4.5	Asynchronous Embedded Format (Class II)	4-7
4.6	Tagged Data Format (Class II)	4-7
4.7	Time Words	4-8
4.8	Asynchronous Data Merge (Class II)	4-10

LIST OF FIGURES

Figure 4-1.	PCM code definitions.	4-3
Figure 4-2.	PCM frame structure.	4-5
Figure 4-3.	16 bit standardized time word format.	4-9
Figure 4-4.	Time word insertion into 12 bit PCM word size.	4-9
Figure 4-5.	Asynchronous word structure.	4-11
Figure 4-6	Overhead truth table.	4-11

This page intentionally left blank.

CHAPTER 4

PULSE CODE MODULATION STANDARDS

4.1 General

Pulse code modulation (PCM) data are transmitted as a serial bit stream of binary-coded time-division multiplexed words. When PCM is transmitted, premodulation filtering shall be used to confine the radiated RF spectrum in accordance with Appendix A. These standards define pulse train structure and system design characteristics for the implementation of PCM telemetry formats. Additional information and recommendations are provided in Appendix C and in RCC Document 119, *Telemetry Applications Handbook*.

4.2 Class Distinctions and Bit-Oriented Characteristics

The PCM formats are divided into two classes for reference. Serial bit stream characteristics are described below prior to frame and word oriented definitions.

4.2.1 Class I and Class II Distinctions. Two classes of PCM formats are covered in this chapter: the basic, simpler types are class I, and the more complex applications are class II. The use of any class II technique requires concurrence of the range involved. All formats with characteristics described in these standards are class I except those identified as class II. The following are examples of class II characteristics.

- a. Bit rates greater than 10 megabits per second (see subparagraph [4.2.2c](#)).
- b. Word lengths in excess of 32 bits (subparagraph [4.3.1a](#)).
- c. Fragmented words (subparagraph [4.3.1b](#)).
- d. More than 8192 bits or 1024 words per minor frame (subparagraph [4.3.2.a\(1\)](#)).
- e. Uneven spacing, not within the definition of subcommutation (subparagraph [4.3.2c](#)) or supercommutation (subparagraph [4.3.2d](#)).
- f. Format changes (paragraph [4.4](#)).
- g. Asynchronous embedded formats (paragraph [4.5](#)).
- h. Tagged data formats (paragraph [4.6](#)).
- i. Formats with data content other than unsigned straight binary, discretized, or complement arithmetic representation for negative numbers such as floating point variables, binary-coded decimal, and gain-and-value.
- j. Asynchronous data transmission (paragraph [4.8](#)).
- k. Merger of multiple format types (such as those specified in Chapter 8).

NOTE



The use of fixed frame formats has been a common practice but does not fit all requirements. A verification of range capabilities should be made prior to incorporation of class II features into a telemetry system.

4.2.2 Bit-Oriented Definitions and Requirements. Definitions and requirements relating to serial PCM bit streams are described next.

- a. Binary Bit Representation. The following code conventions for representing serial binary ones and zeros are the only permissible representations. Graphic and written descriptions of these conventions are shown in Figure 4-1. Only one convention shall be used within a single PCM bit stream. If Randomized NRZ-L (RNRZ-L) is transmitted, it shall use the 15-bit regeneration pattern as described in Appendix D.
 - (1) NRZ-L
 - (2) NRZ-M
 - (3) NRZ-S
 - (4) Bi ϕ -L
 - (5) Bi ϕ -M
 - (6) Bi ϕ -S
- b. Serial Bit Stream Transitions. The transmitted or recorded bit stream shall be continuous and shall contain sufficient transitions to ensure bit acquisition and continued bit synchronization, taking into account the binary representation chosen. See recommendation in Appendix C, paragraph 1.3.
- c. Bit Rate. The RF and recording limits, defined in Chapters 2 and 6, should be considered when determining maximum bit rates. The minimum bit rate shall be 10 bps. Bit rates greater than 10 Mbps are class II.
- d. Bit Rate Accuracy and Stability. During any period of desired data, the bit rate shall not differ from the specified nominal bit rate by more than 0.1 percent of the nominal rate.
- e. Bit Jitter. The bit jitter shall not exceed ± 0.1 of a bit interval referenced to the expected transition time with no jitter. The expected transition time shall be based on the measured average bit period as determined during the immediately preceding 1000 bits.

4.3 Fixed Formats

Characteristics of fixed formats are described below. Fixed formats do not have changes during transmission with regard to frame structure, word length or location, commutation sequence, sample interval, or measurement list.

4.3.1 Word-Oriented Definitions and Requirements. The following definitions and requirements are addressed to word characteristics.

- a. Word Length (Class I and II). Individual words may vary in length from 4 bits to not more than 32 bits in class I and not more than 64 bits in class II.

4-



Code	Logic Waveform Levels	Code Waveforms	Code Definitions
NRZ-L	1 0		<u>Non Return to Zero - Level</u> <ul style="list-style-type: none"> ● “ONE” is represented by one level ● “ZERO” is represented by the other level
NRZ-M	1 0		<u>Non Return to Zero - Mark</u> <ul style="list-style-type: none"> ● “ONE” is represented by a change in level ● “ZERO” is represented by <u>NO</u> change in level
NRZ-S	1 0		<u>Non Return to Zero - Space</u> <ul style="list-style-type: none"> ● “ONE” is represented by <u>NO</u> change in level ● “ZERO” is represented by a change in level
Biφ-L	1 0		<u>Bi-Phase - Level</u> ⁽¹⁾ <ul style="list-style-type: none"> ● “ONE” is represented by a “ONE” level with transition to the “ZERO” level ● “ZERO” is represented by a “ZERO” level with transition to the “ONE” level
Biφ-M	1 0		<u>Bi-Phase - Mark</u> ⁽¹⁾ <ul style="list-style-type: none"> ● “ONE” is represented by <u>NO</u> level change at the beginning of the bit period ● “ZERO” is represented by a level change at the beginning of the bit period
Biφ-S	1 0		<u>Bi-Phase - Space</u> ⁽¹⁾ <ul style="list-style-type: none"> ● “ONE” is represented by a level change at the beginning of the bit period ● “ZERO” is represented by a <u>NO</u> level change at the beginning of the bit period
Note: (1) The Biφ codes may be derived from the corresponding NRZ codes by inverting the level for the last half of each bit interval.			

Figure 4-1. PCM code definitions.

- b. Fragmented Words (Class II). A fragmented word is defined as a word divided into no more than eight segments and placed in various locations within a minor frame. The locations need not be adjacent. All word segments used to form a data word should be constrained to the boundaries of a single minor frame. Fragmented synchronization words are not allowed.
- c. Bit Numbering. To provide consistent notation, the most significant bit in a word shall be numbered “one.” Less significant bits shall be numbered sequentially within the word.
- d. Word Numbering. To provide consistent notation, the first word after the minor frame synchronization pattern shall be numbered “one” (see Figure 4-2). Each subsequent word shall be sequentially numbered within the minor frame. Numbering within a subframe (see subparagraph 4.3.2c(1)) shall be “one” for the word in the same minor frame as the initial counter value for subframe synchronization and sequentially thereafter. Notations of W and S shall mean the W word position in the minor frame and S word position in the subframe.

4.3.2 Frame Structure. The PCM data shall be formatted into fixed length frames as defined in these sections regarding frame structure and in Figure 4-2. Frames shall contain a fixed number of equal duration bit intervals.

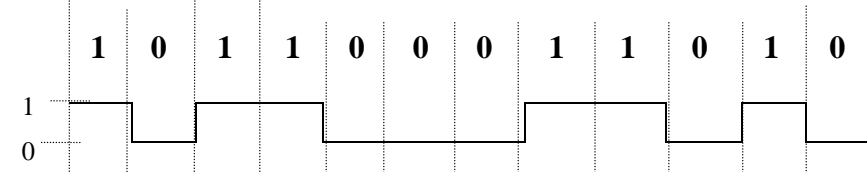
- a. Minor Frame. The minor frame is defined as the data structure in time sequence from the beginning of a minor frame synchronization pattern to the beginning of the next minor frame synchronization pattern.
 - (1) Minor Frame Length (Class I and II). The minor frame length is the number of bit intervals from the beginning of the frame synchronization pattern to the beginning of the next synchronization pattern. The maximum length of a minor frame shall exceed neither 8192 bits nor 1024 words in class I and shall not exceed 16384 bits in class II.
 - (2) Minor Frame Composition. The minor frame shall contain the minor frame synchronization pattern, data words, and subframe synchronization words, if used. Words of different length may be multiplexed in a single minor frame. The length of a word in any identified word position within a minor frame shall be constant. Other words such as frame format identifiers may be needed within class II formats (see paragraph 4.4).
 - (3) Minor Frame Synchronization. The minor frame synchronization information shall consist of a fixed digital word not longer than 33 consecutive bits and not shorter than 16 bits. The minor frame synchronization pattern is always considered as one word, regardless of its length. Recommended synchronization patterns are given in Table C-1, Appendix C.
 - (4) Transmitted Frame Counter. The frame counter provides a natural binary count corresponding to the minor frame number in which the frame count word appears. It is recommended that such a counter be included in all minor frames whether class I or class II and is especially desirable in class II formats to assist with data processing. The frame counter should be of nominal format word length and reset

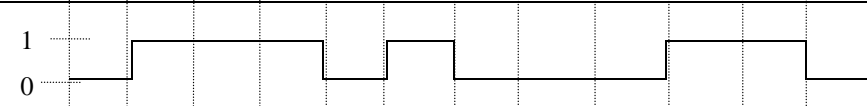
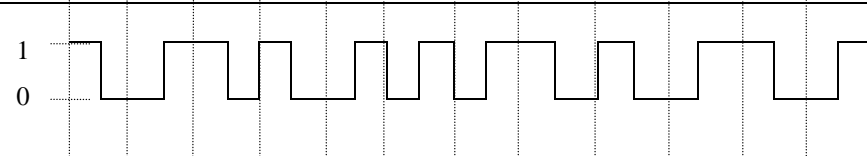
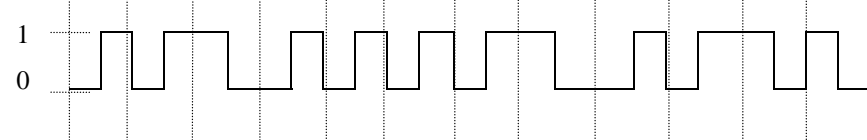
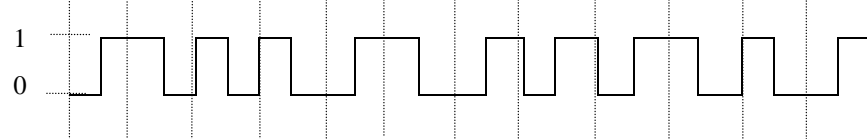
to start up-counting again after reaching maximum value. In formats where subcommutation is present, the subframe ID counter may serve as the frame counter.

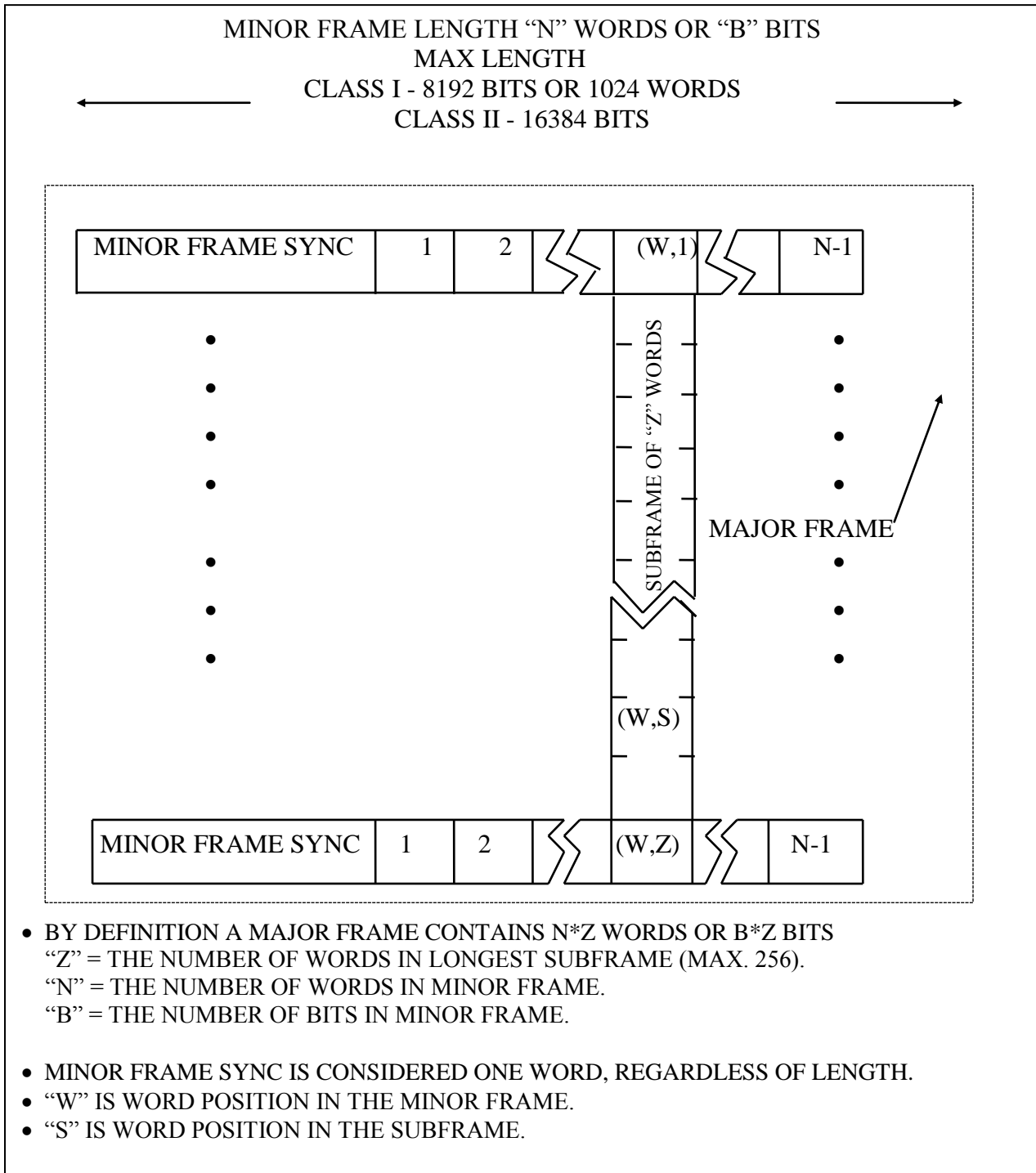

Figure 4-2. PCM frame structure.

- b. Major Frame. A major frame contains the number of minor frames required to include one sample of every parameter in the format.
 - (1) Major Frame Length. Major frame length is defined as minor frame length (N words or B bits) multiplied by the number of minor frames (Z) in the major frame. The maximum number of minor frames per major frame shall not exceed 256.
 - (2) Minor Frame Numbering. To provide consistent notation, the first minor frame in a major frame shall be numbered “one.” Each subsequent minor frame shall be numbered sequentially within the major frame.

- c. Subcommutation. Subcommutation is defined as a sampling of parameters at submultiple rates (1/D) of the minor frame rate where the depth of a subframe, D, is an integer in the range of 2 to Z.
 - (1) Subframe. Subframe is defined as one cycle of the parameters from a subcommutated minor frame word position. The depth, D, of a subframe is the number of minor frames in one cycle before repetition.
 - (2) Subframe Synchronization Method. The standard method for subframe synchronization is to use a “subframe ID counter,” a binary counter which counts sequentially up or down at the minor frame rate. Typically, only one subframe ID counter is used in a PCM format; however, more than one counter may be used if needed. This paragraph assumes the use of one subframe ID counter. The subframe ID counter shall be located in a fixed position in each and every minor frame. The counter should start with the minimum counter value when counting up or the maximum counter value when counting down. The counter should also be left or right justified in a word position. The start of a major frame shall coincide with the initial count for the deepest subframe.

- d. Supercommutation. Supercommutation (“supercom”) is defined as time-division-multiplex sampling at a rate that is a multiple of the minor frame rate. Supercommutation (on a minor frame) provides multiple samples of the same parameter in each minor frame. “Supercom on a subframe” is defined as time-division-multiplex sampling at a rate that is a multiple of the subframe rate and provides multiple samples of the same parameter within a subframe. For class I, supercommutated samples shall be evenly spaced. For class II, supercommutated samples should be as evenly spaced as practical.

4.4 Format Change (Class II)

Format change is defined as change with regard to frame structure, word length or location, commutation sequence, sample interval, or change in measurement list. Format changes shall occur only on minor frame boundaries. Bit synchronization shall be maintained and fill bits used instead of intentional dead periods. Format changes are inherently disruptive to test data processing; fixed format methods are preferred. Format change methods shall conform to the characteristics described in the following sections.

4.4.1 Frame Format Identification. A frame format identifier (FFI) is a word that shall uniquely identify a single format. In formats where change is required, the frame format identifier shall be placed in every minor frame. The format identifier shall be the same length as

(or multiples of) the most common word length in the format and shall occur in a fixed position in the minor frame. The FFI shall identify the format applicable to the current minor frame. Frame synchronization pattern, FFI location, bit rate, and binary bit representation code shall not be changed. The FFI shall be constructed such that a single bit error cannot produce another valid FFI. The number of unique formats indicated shall not exceed 16.

4.4.2 Format Change Implementation Methods. The following subparagraphs describe format change implementation methods.

- a. Measurement List Change. This method of format change consists of a modification in data content only and not format structure.
- b. Format Structure Change. Defined as a format change where there is a departure in frame structure and not just data content.

4.5 Asynchronous Embedded Format (Class II)

An asynchronous embedded format is defined as a secondary data stream asynchronously embedded into a host major frame in a manner that does not allow predicting the location of embedded synchronization information based only on host format timing. It is recommended that the embedded frame segments be inserted as an integral number of words in every host minor frame, so that in the combined format, specific word positions in the host minor frame are dedicated to the embedded asynchronous format. However, placing the asynchronous embedded format only in selected host minor frames is permitted. It is also recommended that no more than two asynchronous embedded formats be inserted in a host major frame, but more than two are permitted.

4.6 Tagged Data Format (Class II)

A tagged data format is defined as a fixed frame length format having no applicable subframe or major frame definitions and characterized as a stream of data words, or blocks of words, with associated identifiers (tags). These formats consist of frame synchronization patterns, identifiers, data words, and fill words as required.

4.6.1 Alternating Tag and Data. This tagged data format consists of frames containing tag words alternating in time sequence with data words or blocks of words identified by the tags.

4.6.2 Bus Data, Military Standard (MIL-STD) 1553.¹ The preferred method of telemetering MIL-STD 1553 information is for the information to be restructured to conform to Class I methods. If not restructured, telemetered MIL-STD 1553 data shall conform to Chapter 8.

4.6.3 Bus Data, ARINC 429.² The preferred method of telemetering ARINC 429 information is for the information to be restructured to conform to Class I methods. If not restructured,

¹ Defined in MIL-HDBK-1553A (Notice 2), 23 March 1995, Multiplex Applications Handbook.

² Defined in ARINC Specification 429P1, 429P2, and 429P3.

telemetered ARINC 429 data shall be consistent with the Aeronautical Radio Inc. specification of ARINC 429 bus data, as implemented in Chapter 8.

4.7 Time Words

The following paragraphs describe the formatting of time words within a PCM stream. A 16-bit standardized time word format and a method to insert time words into PCM word sizes other than 16-bits are described.

4.7.1 In 16-bit standardized time word format, there shall be three words dedicated to providing timing information. These words are designated high order time, low order time, and microsecond time. High and low order time words shall be binary or binary coded decimal (BCD) weighted, and microsecond words shall be binary weighted. Time word construction examples are shown in Figure [4-3](#) and Figure [4-4](#).

4.7.2 The microsecond time word shall have a resolution of 1 microsecond; that is, the least significant bit, bit 16, has a value of 0.000001 second. This word shall increment until it attains a value of 10 milliseconds at which time it will reset to zero. Thus the maximum value of the counter is 9999 (decimal).

4.7.3 The low order time word shall have a resolution of 10 milliseconds; that is, the least significant bit, bit 16, of the low order time word shall have a value of 0.01 second.

4.7.4 The high order time word shall have a resolution of 655.36 seconds when binary weighted; that is, the least significant bit, bit 16, has a value of 655.36 seconds. When BCD weighted, the least significant bit, bit 16, of the high order time word shall have a value of one minute. For BCD, the days field shall contain the three least significant characters of the BCD Julian date.

4.7.5 It is recommended that high, low, and microsecond time words precede the first data word in the minor frame. The time word order shall be high order time word, followed by low order time word, followed by microsecond time word. Microsecond time words may be used to tag individual data words, but care shall be taken that high order and low order time words be inserted at a rate necessary to resolve time ambiguities.

4.7.6 Time word insertion into PCM word sizes other than 16 bits shall be as follows: high order, low order, and microsecond time words shall be inserted into PCM words with time word bits occupying contiguous bit locations in the PCM word. The time word shall occupy contiguous PCM data words until the time word is contained in the PCM stream. If the time word size is not an integer multiple of the PCM word size and there are unused bits in the PCM word, the remaining unused bits in the last PCM word that contains the time word shall be fill bits with value 0. Figure [4-4](#) illustrates the insertion of time words into a PCM stream with word size of 12 bits.

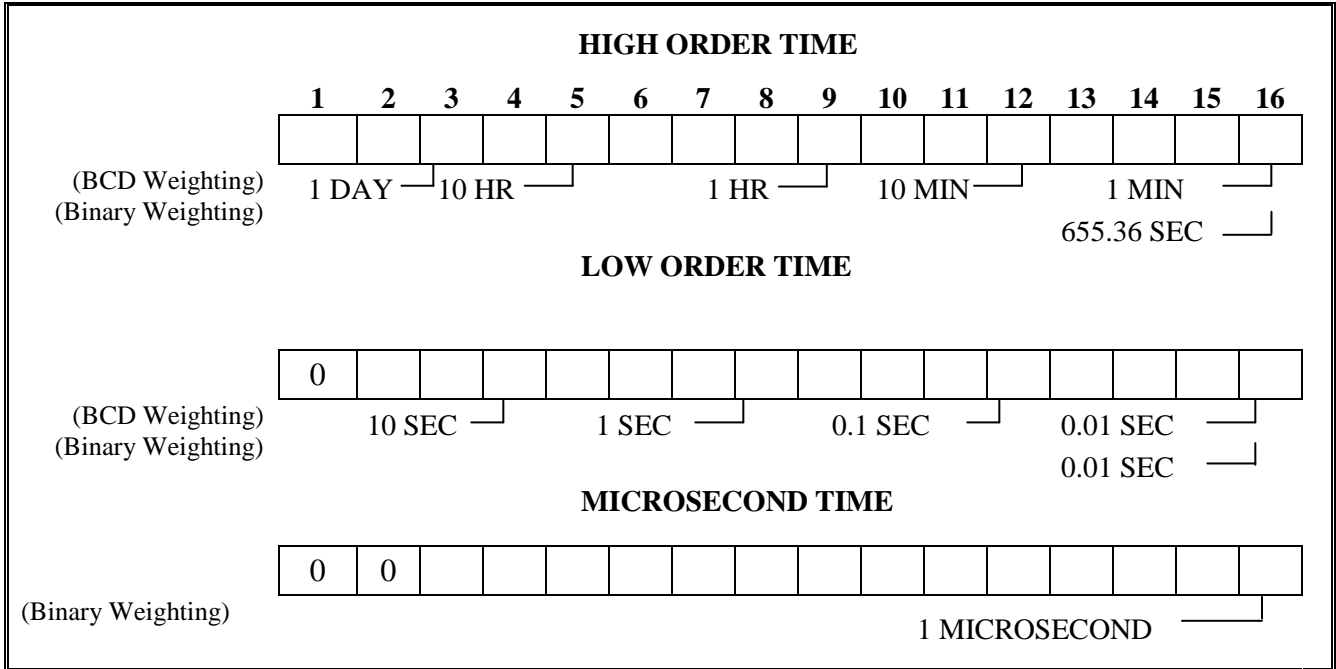

Figure 4-3. 16 bit standardized time word format.

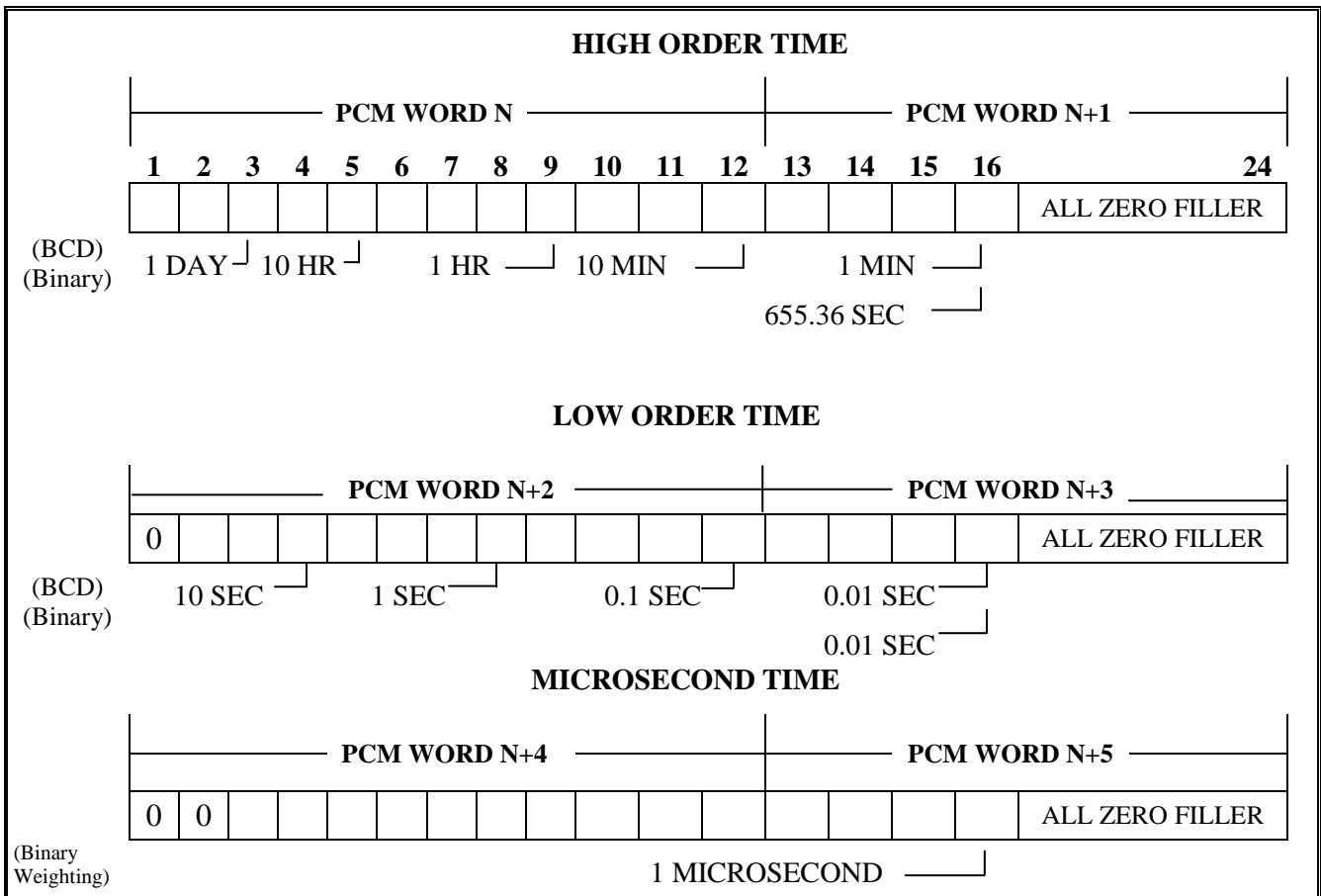

Figure 4-4. Time word insertion into 12 bit PCM word size.

4.8 Asynchronous Data Merge (Class II)

Asynchronous data is defined as an external sequential data stream (consisting of data bits, associated overhead, and optional parity, all at an autonomous update rate) which is a candidate for insertion into a primary or “host” PCM format. Common examples are RS-232 serial and IEEE-488 parallel messages. This section does not apply to secondary PCM formats which are to be embedded as described in paragraph 4.5. Merger shall comply with subparagraph 4.2.2.

Each source of merged data shall use fixed word positions in the host format. It is recommended that the merged data be inserted as an integral number of words in every host minor frame, so that in the combined format, specific word positions in the host minor frame are dedicated to the merged data format. However, placing the merged data format only in selected host minor frames is permitted. It is also recommended that no more than two merged data formats be inserted in a host major frame, but more than two are permitted. The following conventions are recommended, but variations are allowed.

4.8.1 PCM Data Word Format. Figure 4-5 illustrates the host PCM format word containing a merged asynchronous data word and associated overhead which is referred to as an “asynchronous word structure.” The data may be inserted in any length PCM word that will accommodate the required bits. Asynchronous data shall not be placed in fragmented words. Multiple host PCM format words, if used, shall be contiguous.

4.8.2 Insertion Process. The asynchronous word structure shall contain the information from the asynchronous message partitioned into two fields, data and overhead, as shown in figure 4-5. The asynchronous message is inserted into the asynchronous word structure with the following bit orientations. The most significant data bit (MSB) through least significant data bit (LSB) and parity (if used) of the message are denoted as D1 (MSB) through D_i and will be inserted into structure bits B1 (MSB) through B_i . The next two structure bits, $B_{(i+1)}$ and $B_{(i+2)}$ are reserved for the stale and overflow flags generated by the host encoder. All remaining overhead (message and host encoder generated) $D_{(i+3)}$ through D_n (LSB), will be inserted into structure bits $B_{(i+3)}$ through B_n (LSB).

- a. Transmission Overhead. All transmission overhead not required for data reconstruction shall be removed.
- b. Parity Bit. Transmission of a parity bit is optional. If it is transmitted, it shall be at the end of the data field (see Figure 4-5) adjacent to the LSB of the data.
- c. Data Bits. The data bits shall be inserted into the PCM word with the most significant bit of the asynchronous data aligned with the most significant bit of the PCM word.

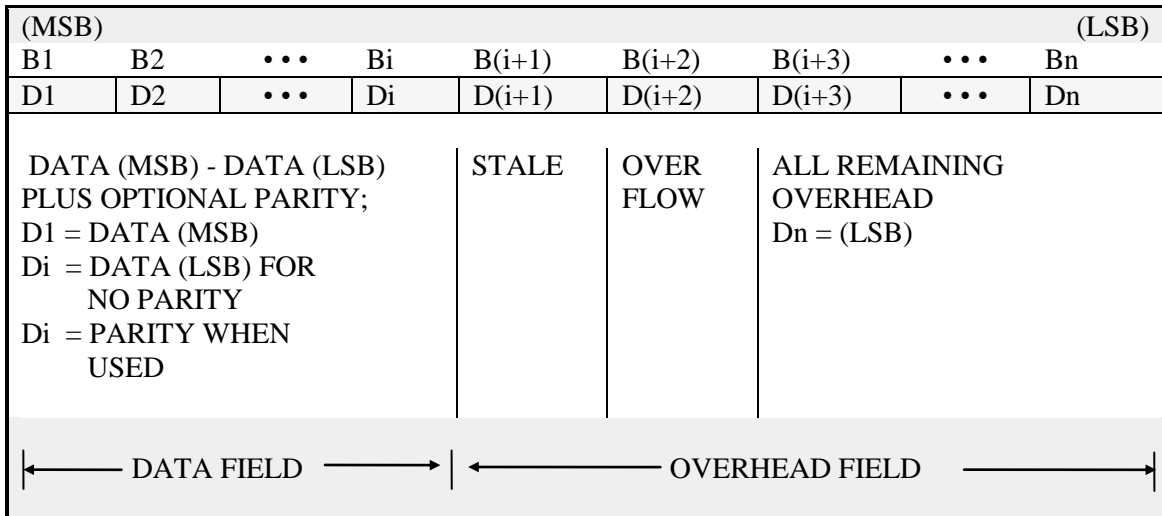

Figure 4-5. Asynchronous word structure.

- d. **Stale Data Bit.** A “stale data bit” flag shall be generated each time a new data value is inserted into the PCM stream. The flag shall be transmitted with the associated data. The flag bit shall be placed in the next less significant bit location following the LSB of the data. If new data is not ready for transmission by the time the PCM word must be sent again, either the old data or alternating one/zero fill shall be sent and the flag set. Stale data shall be indicated by a binary “one” (see Figure 4-6).

STALE BIT	OVERFLOW BIT	
0	0	FRESH DATA
0	1	DATA OVERFLOW
1	0	STALE DATA
1	1	USER DEFINED

Figure 4-6. Overhead truth table.

- e. **Overflow Bit.** An “overflow bit” flag shall be generated to indicate an abnormal condition in which data may be lost. The overflow bit shall be placed in the next less significant data bit location following the stale bit flag. An overflow bit at a binary “one” indicates that a data discontinuity exists between the current data word and the previous data word (see Figure 4-6 above).
- f. **Insertion Rate.** The asynchronous word structure shall be inserted into the host PCM word at a rate to avoid data loss in the PCM stream.

****** END OF CHAPTER 4 ******